



Convey Redirect Divert

High quality industrial conveyor systems for handling of bottles, cans, bags, and cartons. Robust and low maintenance energy efficient systems. Our industrial conveyor systems are designed and build in Icon's Melbourne facility in Australia.

CONVEYOR

Entry level stand alone conveyors or specialty stations with integrated control. Simply add an Icon conveyor into your current workflow.

SYSTEMS

Efficient solutions for fully integrated line solutions. Full turnkey projects with complete line control. Layout design or modifications & additions to existing lines.

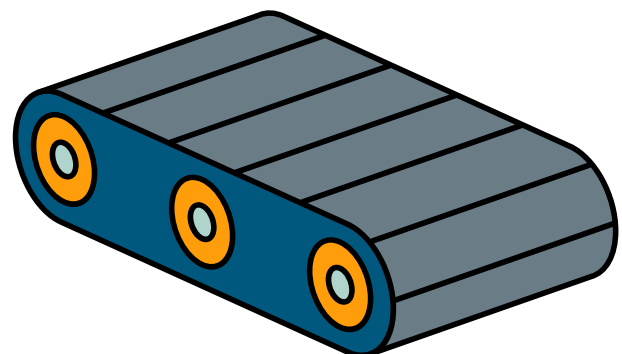

More Info:

www.iconequip.com.au/conveyors

For more info +61 3 9462 1544 or enquiries@iconequip.com.au



Icon has been designing, modifying and integrating their conveyor systems and specialty stations for decades. Icon supplies fully integrated customised solutions as well as stand alone conveyor systems for all applications. Our systems are specifically design for the food and beverage industry with the highest quality and hygiene and standards.

Features

- Various speed and load options
- Integrated into line control
- Motor gearbox options
- Power efficient and low friction options
- Easy to Adjust
- Accumulation options
- Overhead options
- Industrial conveyors designed and build in Australia



Fast Delivery

Inhouse production



Custom Solutions

Any line, any function, any speed



Easy Adjust

No need for special skills or tools



Quality Construction

Robust design for industrial applications



More Info:

www.iconequip.com.au/conveyors

For more info +61 3 9462 1544 or enquiries@iconequip.com.au

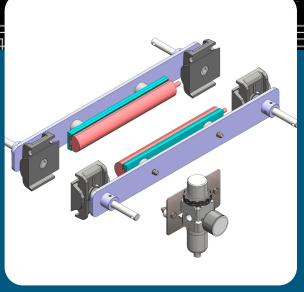
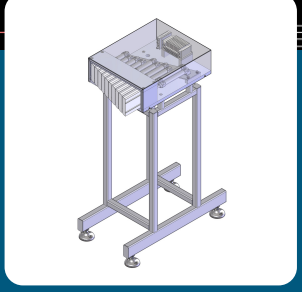
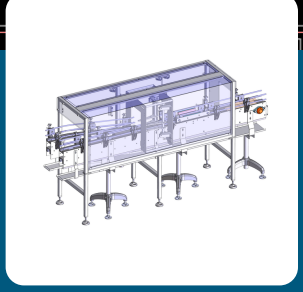
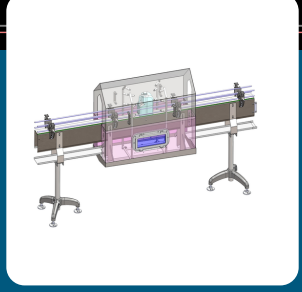
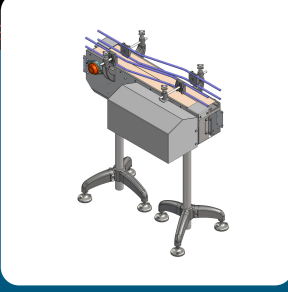
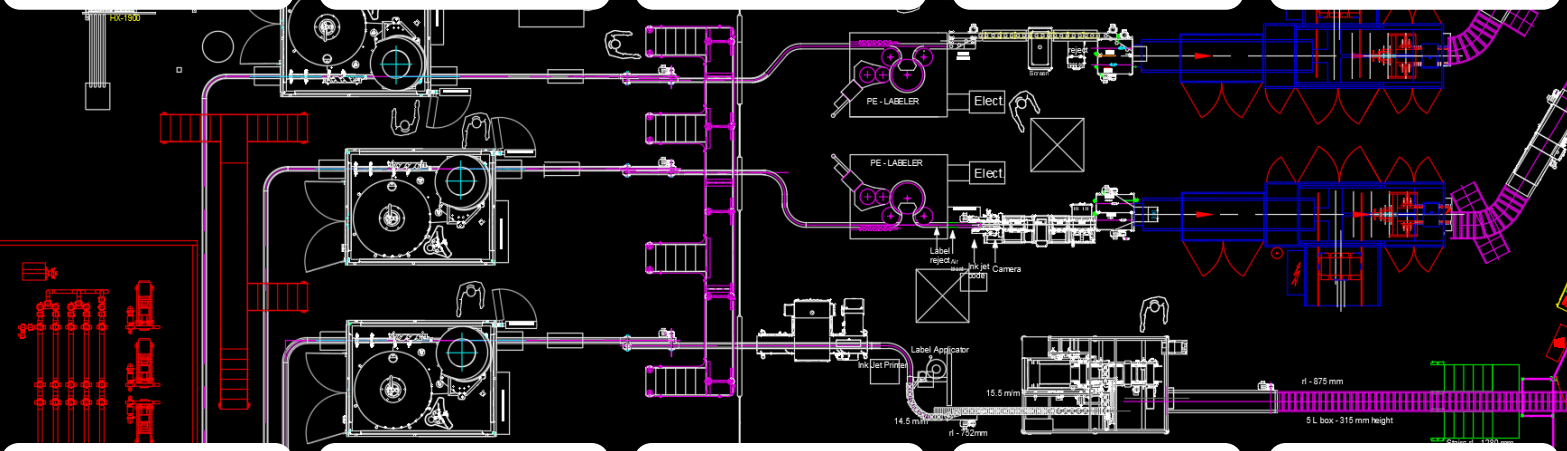
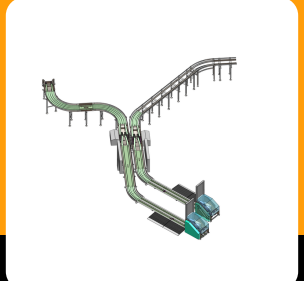
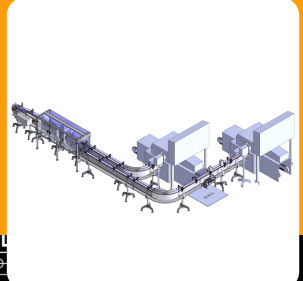

More Info:
www.iconequip.com.au/conveyors

For more info +61 3 9462 1544 or enquiries@iconequip.com.au

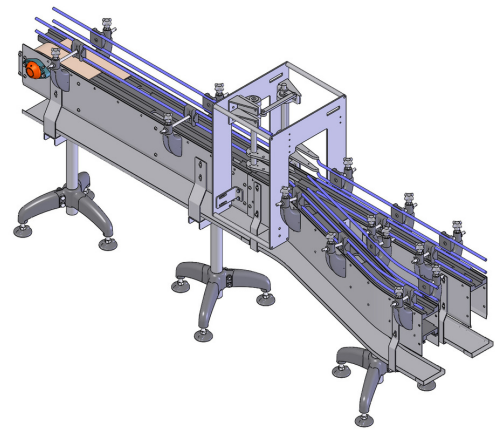
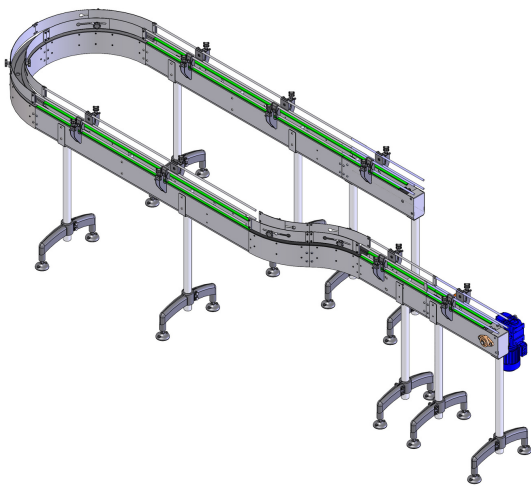

Icon Equipment has an extensive range of spare parts for a wide variety of packaging equipment. Our inventory consists only of the highest quality spare parts which we manufacture inhouse throughout our Australian operations or sourced through our reliable partners.



Conveyors & Accessories

Include:

- Infeed conveyors
- Outfeed conveyors
- Slat, belt & roller conveyors
- Reject Stations
- Rinse stations
- Bottle stop stations
- Straight conveyors
- Diverging & Converging conveyors
- Crate conveyors

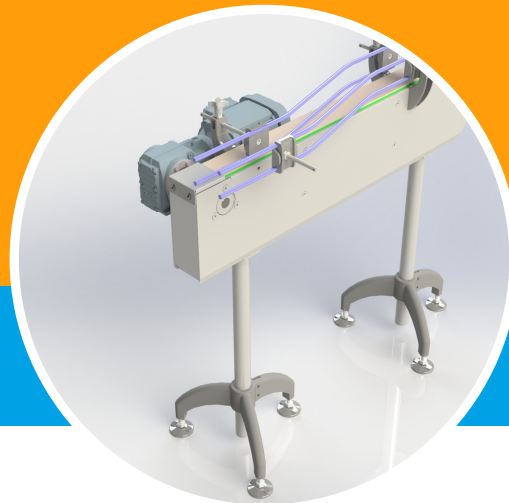

CHECK US OUT

WWW.ICONEQUIP.COM.AU

More Info:

www.iconequip.com.au/conveyors

For more info +61 3 9462 1544 or enquiries@iconequip.com.au